

SECTION 1: CONSTRUCTION

SWPPP CUT SHEET

Filtrex[®] Sediment Trap (SiltSoxx[™])

PURPOSE & DESCRIPTION

Filtrex[®] SiltSoxx[™] is a three-dimensional tubular runoff and erosion control device used for Filtrex[®] Sediment traps - temporary **dry pond sediment containment detention systems** used to capture sediment and settle suspended solids in runoff from disturbed soils less than 5 acres (2 ha). Sediment traps are also used to capture sediment and settle suspended solids from **detention pond outfalls** and/or potential overflows.

APPLICATION

Sediment traps are typically installed down slope from disturbed soils where runoff capture and detention is feasible and settling of suspended solids is required; or where post-construction storm water runoff quality is a concern and pollutant reduction and/or LID practices are required.

Applications include:

- Individual sediment detention & containment zones where drainage areas do not exceed 5 acres (2 ha).
- Sediment and storm water detention pond outfall channels where additional removal of sediments and soluble pollutants are required before final discharge.
- Emergency overflow for retention or detention sediment or storm water containment systems.
- Where land area is limited or land disturbance, grading, and/or construction of a sediment pond is undesirable or not feasible.
- Where sediment particle sizes are predominantly greater than 0.002 mm (clay).
- Where post-construction storm water turbidity, TSS, phosphorus, nitrogen, bacteria, heavy metals, or petroleum hydrocarbons need to be removed prior to discharge or entry into receiving waters.

INSTALLATION

1. Sediment traps shall meet Filtrex Soxx Material Specifications and use Filtrex[®] CertifiedSM FilterMedia.
2. Contractor is required to be a Filtrex[®] CertifiedSM

Installer as determined by Filtrex International (877-542-7699). Certification shall be considered current if appropriate identification is shown during time of bid or at time of application. Look for the Filtrex[®] CertifiedSM Installer Seal.

3. Sediment traps will be placed at locations indicated on plans as directed by the Engineer.
4. Sediment traps shall not be placed on fill soil or slopes, soft, or uneven ground.
5. Sediment traps must be installed on level contours. Field verification with laser level is strongly recommended.
6. Sediment traps should be installed at the base of the drainage area.
7. Filtrex Runoff Diversion can be installed to divert runoff flows from undisturbed or stabilized areas from entering design area of sediment trap.
8. Filtrex Slope Interruption may be installed upslope and with the runoff flow path to reduce flow energy entering sediment traps.
9. Concentrated flows, channels, or ditches directing flow into sediment traps shall employ energy flow dissipaters prior to flow contact with Soxx or entry into the sediment trap system. Dissipaters shall be placed at a minimum distance of 20 ft (6 m) from the base course of the sediment trap.
10. Sediment traps shall be installed so the effective height is at least 3 ft (90 cm).
11. Ends of sediment traps shall be at least 1 ft (30cm) higher in elevation than the mid-section. The mid-section shall be the lowest point of the trap.
12. Sediment traps shall be constructed so the horizontal base width is at least equivalent to the effective height (1H:1V).
13. Sediment traps sized and specified by fascia design area shall be installed so that the height is measured vertically not across the plane of the sediment trap face.
14. Additional runoff-sediment storage area can be created by over excavating the area immediately upslope of the sediment trap.
15. Soxx that are sleeved to create longer lengths shall not be placed in areas of concentrated flow, at the base of channels/ditches, or at the low point with



- the sediment trap system.
16. Soxx that are sleeved to create longer lengths shall be overlapped by a minimum of 4 ft (120 cm) and shall be staked where material over laps using 2 stakes 2 ft (60 cm) apart.
 17. Stakes shall be installed through the middle of the Soxx using 2 in (50mm) by 2 in (50mm) by 3 ft (1m) wooden hardwood stakes on 10 ft (3 m) centers; 5 ft (1.5 m) on center staking may be used to increase stability. Stakes shall be placed in a pyramid configuration perpendicular to Soxx where stakes cross at the apex of the sediment trap. Stakes shall be joined and secured with wire wrapping at apex using 16 gauge or multi-strand 20 gauge wire allowing 12 in (30cm) of stake above the Soxx. All base layers shall be staked on 5 ft (1.5 m) centers. All base layers shall be staked on 5 ft (1.5 m) centers; placed opposite the pyramid staking; where staking is present every 2.5 ft (0.75 m). Half inch (12.5 mm) rebar may also be used when ground is frozen or extremely compacted.
 18. Staking depth for all soil types shall be minimum 12 in (300mm) into native soil.
 19. Soxx to receive additional layers shall be slightly compacted and leveled.
 20. Loose FilterMedia shall be backfilled along the upslope side of the sediment trap, along seams, and within void spaces; thereby filling the seam between the soil surface and the sediment trap, improving sediment containment, and reducing undercutting potential.
 21. If the sediment trap is to be left as a permanent filter or part of the natural landscape, it may be seeded at time of installation for establishment of permanent vegetation. The Engineer will specify seed requirements.
 22. Sediment traps are not to be used in perennial, ephemeral, or intermittent streams.

See design drawing schematic for correct Filtrex[®] Sediment trap installation (Figure 9.1).

INSPECTION AND MAINTENANCE

Routine inspection should be conducted within 24 hrs of a runoff event or as designated by the regulating authority. If ponding becomes excessive, additional Sediment traps may be required to reduce effective drainage area or sediment removal may be necessary.

1. The Contractor shall maintain the sediment trap in a functional condition at all times and it shall be routinely inspected.

2. If the sediment trap has been damaged, it shall be repaired, or replaced if beyond repair.
3. The Contractor shall remove sediment at the base of the upslope side of the sediment trap when accumulation has reached 1/2 of the effective height of the sediment trap, or as directed by the Engineer. Alternatively, a new Soxx can be placed on top of the original structure creating more sediment storage capacity without soil disturbance.
4. Sediment traps shall be maintained until disturbed area above the device has been permanently stabilized and construction activity has ceased.
5. The FilterMedia will be dispersed on site once disturbed area has been permanently stabilized, construction activity has ceased, or as determined by the Engineer.
6. For long-term sediment and pollution control applications, sediment traps can be seeded at the time of installation to create a vegetative filtering system for prolonged and increased filtration of sediment and soluble pollutants (contained vegetative filter strip). The appropriate seed mix shall be determined by the Engineer.

ADDITIONAL INFORMATION

For other references on this topic, including additional research reports and trade magazine and press coverage, visit the Filtrex website at www.filtrex.com

Filtrex International, Technical Support
61 N Clev-Mass Rd, Ste E, Akron, OH 44333
877-542-7699 | 234-466-0810 (fax)
www.filtrex.com | info@filtrex.com
Call for complete list of international installers.

Filtrex and Let Nature Do It are Registered Trademarks of Filtrex International.

FilterMedia, FilterSoxx, GrowingMedia, SiltSoxx, and Soxx are Trademarks of Filtrex International.

Filtrex Certified and its accompanying logo are Service Marks of Filtrex International.

The information contained herein may be subject to confidential intellectual property of Filtrex International, including but not limited to US Patents 7,226,240; 7,452,165; 7,654,292; 8,272,812; 8,439,607; 8,740,503; 8,821,076; and 9,044,795 or Patents Pending and is the property of Filtrex International.

Copyright 2005-2017, Filtrex International, all rights reserved. Unauthorized reproduction prohibited.



Figure 9.1. Engineer Design Drawing for Sediment Trap.

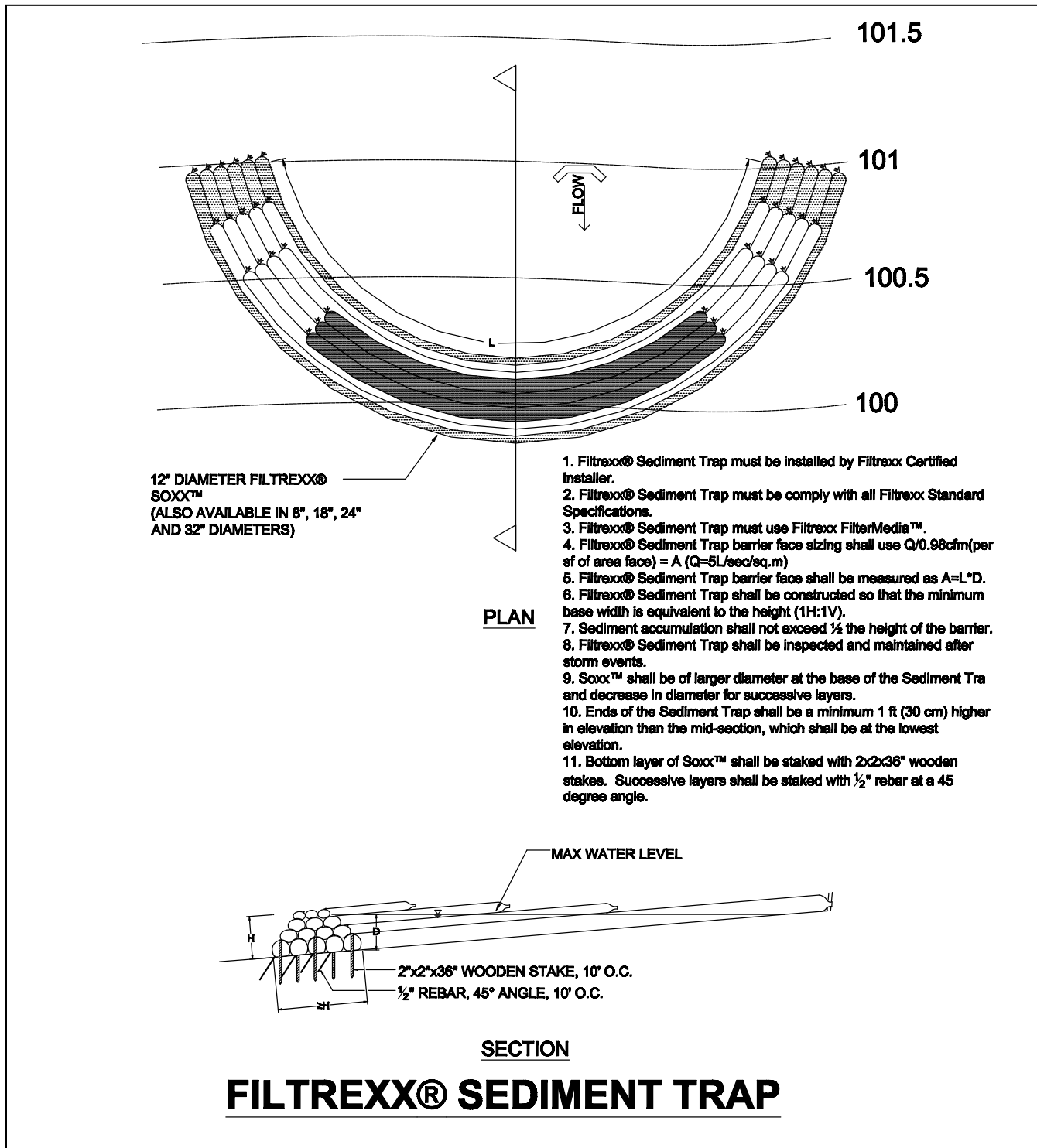

Figure 9.2. Engineer Design Detail for Staking Sediment Trap.

