

## SECTION 2: POST-CONSTRUCTION

### SWPPP CUT SHEET

#### Filtrex<sup>®</sup> Channel Protection (GroSoxx<sup>®</sup>)

##### PURPOSE & DESCRIPTION

The **Filtrex<sup>®</sup> Channel Protection** soft armoring system is designed to stabilize and prevent erosion of channel beds and banks used for storm water conveyance and concentrated flow situations. The channel protection technology provides structural protection, erosion control, vegetation growth, and vegetation reinforcement in the same system. The channel protection weight and anchoring system can withstand storm runoff velocities and hydraulic shear stresses similar to traditional soft armoring devices (turf reinforcement mats, rip rap, cellular confinement systems). Channel protection uses GroSoxx<sup>®</sup> - Filtrex<sup>®</sup> Soxx<sup>™</sup> mesh, filled with composted Filtrex<sup>®</sup> GrowingMedia<sup>™</sup>.

The vegetated channel protection system is specifically designed to reinforce vegetation against intense hydraulic pressure. Once permanent vegetation is established in the channel protection, the following storm water management parameters are increased:

- structural stability of the channel and protection system,
- reduction of bed and bank erosion,
- protection from scour erosion,
- control of runoff velocity,
- dissipation of runoff energy,
- sediment, soluble pollutant, and pathogen removal efficiency

##### APPLICATION

Channel protection is used where storm water is conveyed or channeled and soil erosion and/or vegetation stability is an issue. Channel protection can be used to establish, sustain, and reinforce vegetation in areas of concentrated flow and intense hydraulic pressure that typically undermine vegetation growth. Applications where channel protection is typically required include:

- storm water diversion channels and ditches,
- storm water conveyance channels and ditches,
- channel/ditch bed and bank protection, and
- outlet protection for storm drains, paved channels, and culverts.

##### INSTALLATION

1. Channel protection shall meet Filtrex Specifications and use Filtrex GrowingMedia.
2. Contractor is required to be a Filtrex<sup>®</sup> Certified<sup>SM</sup> Installer as determined by Filtrex International (877-542-7699). Certification shall be considered current if appropriate identification is shown during time of bid or at time of application. Look for the Filtrex Certified Installer Seal.
3. Channel protection will be placed at locations indicated on plans as directed by the Engineer.
4. Channel protection must be installed and stabilized before flow is allowed from culverts and storm outlets.
5. Land surface shall be cleared of debris, including rocks, roots, large clods, and sticks prior to channel protection installation.
6. Channel bed shall be made smooth prior to installation of channel protection.
7. Soil bed may be compacted and graded prior to installation.
8. The upslope end of the channel protection shall be installed under the lip of the culvert or outlet drain to ensure initial storm flow contact is on top of the channel protection, not under or in front of the system.
9. Channel protection will be fabricated on-site or prefabricated and delivered to site for installation.
10. Channel protection will be fabricated to ensure 3 in (75mm) high by 12 in (300mm) wide Soxx construction configuration is met.
11. Channel protection shall be placed parallel to water flow, where socks are tightly abutted to prevent water seepage between and underneath the channel protection.
12. Once in place, channel protection shall be lightly compacted and abutting edges leveled to tighten seal between socks and encourage even water flow over channel protection system.
13. Channel protection shall not be installed on channel bed slopes greater than 10%.
14. Channel protection shall not be installed on



- channel banks greater than 2:1, and banks 3:1 if mowing will be conducted to manage vegetation.
15. Stakes shall be installed through the middle of the Channel protection on 10 ft (3m) centers, using 2 in (50mm) by 2 in (50mm) by 3 ft (1m) wooden stakes. Top of stakes should be cut off, leaving 3 in (75mm) above the top of the channel protection.
  16. Alternatively, L-shaped rebar may be installed through the middle of the channel protection on 10 ft (3m) centers, where the “L” shall be bent to form a hook over the top of the channel protection and pounded to fit snug.
  17. Stakes shall also be placed at the ends of channel protection to hold it in place.
  18. Staking depth for sand and silt loam soils shall be 12 in (300mm), and 8 in (200mm) for clay soils.
  19. Channel protection may be seeded at the time of application, seed selection will be determined by the Engineer.
  20. Seeded channel protection should not be installed prior to seasons where growing vegetation is difficult.
  21. Seed shall be thoroughly mixed with the GrowingMedia prior to construction or injected into GrowingMedia at time of application.
  22. Optional biotechnical engineering with live stakes should be conducted after staking is complete.
  23. Seeded channel protection shall be thoroughly watered after installation and allowed to settle for 1 week.

### INSPECTION AND MAINTENANCE

Routine inspection should be conducted within 24 hours of a runoff event for the first year after installation, until permanent vegetation has established, or as designated by the regulating authority. If product dislodgement occurs, or vegetation does not establish, channel protection should be repaired and/or reseeded. If bank or bed erosion occurs, the area should be repaired immediately. Vegetation practices should always be inspected for noxious or invasive weeds. If sediment accumulation is 25% of the height of the vegetation, sediment removal is recommended. Storm debris and trash should be removed immediately.

1. The Contractor shall maintain the channel protection in a functional condition at all times and it shall be routinely inspected.
2. Seeded channel protection shall be maintained until a uniform 70% minimum cover of the applied area has been vegetated, permanent vegetation has established, or as required by the jurisdictional agency.

3. Seeded channel protection may need to be irrigated in hot and dry weather and seasons, or arid and semi-arid climates to ensure vegetation establishment.
4. Where channel protection fails or becomes dislodged, the contractor will ensure the product is in good contact with the soil, repair, and use additional staking if necessary.
5. Where bank or bed erosion occurs, the contractor will regrade the soil if necessary and repair or replace the channel protection.
6. Where vegetation does not establish the contractor will reseed, replant, or provide an approved and functioning alternative.
7. No additional fertilizer or lime is required for vegetation establishment and maintenance.
8. No disposal is required for this product/practice.
9. Channel protection shall be left on-site and become part of the permanent landscape, unless otherwise specified by the Engineer.
10. Regular mowing of grass vegetation on seeded channel protection to a minimum height of 4 in (100mm) and a maximum height of 10 in (250mm) will deter invasive weeds, allow sunlight to kill captured pathogens, and provide maximum sediment removal efficiency and sediment storage capacity in the vegetation.
11. Storm debris and trash deposited on channel protection should be removed immediately.
12. Sediment shall be removed if it reaches 25% of the height of the vegetation (mowed) to prevent diversion of storm runoff and reduction of vegetation health and cover.

### ADDITIONAL INFORMATION

For other references on this topic, including additional research reports and trade magazine and press coverage, visit the Filtrexx website at [www.filtrexx.com](http://www.filtrexx.com)

Filtrexx International, Technical Support  
 61 N Clev-Mass Rd, Ste E, Akron, OH 44333  
 877-542-7699 | 234-466-0810 (fax)  
[www.filtrexx.com](http://www.filtrexx.com) | [info@filtrexx.com](mailto:info@filtrexx.com)  
 Call for complete list of international installers.

Filtrexx, GroSoxx, and Let Nature Do It are Registered Trademarks of Filtrexx International. FilterSoxx, GrowingMedia and Soxx are Trademarks of Filtrexx International. Filtrexx Certified and its accompanying logo are Service Marks of Filtrexx International.

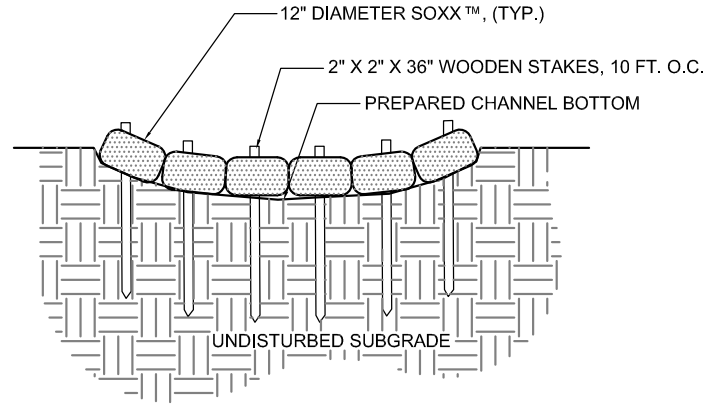
The information contained herein may be subject to confidential intellectual property of Filtrexx International, including but not limited to US Patents 7,226,240; 7,452,165; 7,654,292; 8,272,812; 8,439,607; 8,740,503; 8,821,076; and 9,044,795 or Patents Pending and is the property of Filtrexx International.

Copyright 2005-2017, Filtrexx International, all rights reserved. Unauthorized reproduction prohibited.

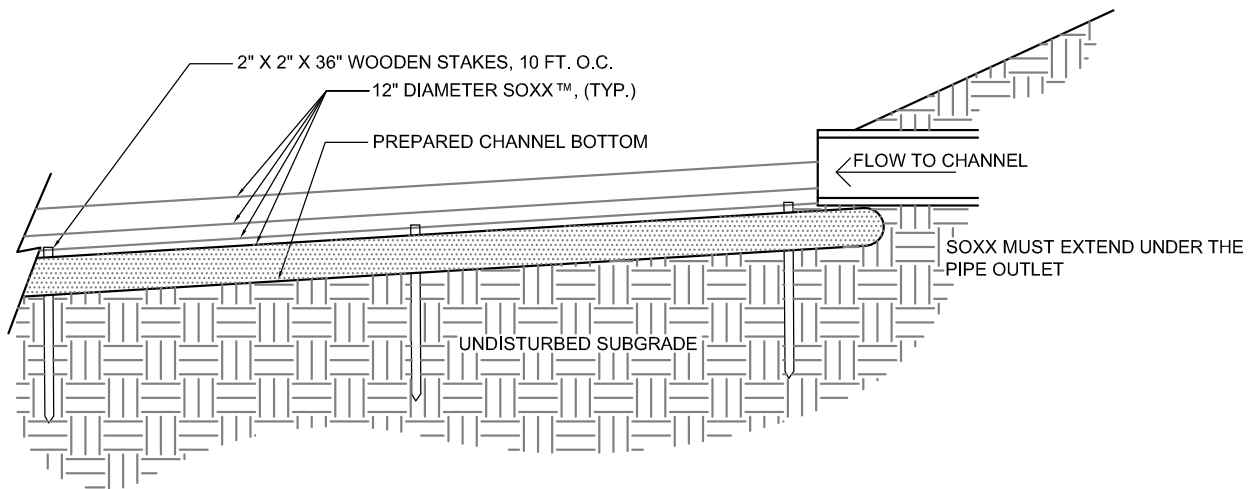


Figure 4.1. Engineering Design Drawings for Filtrexx Channel Protection

1. Soxx™ shall meet Filtrexx Soxx™ Specifications and use Filtrexx GrowingMedia™.
2. Contractor is required to be a Filtrexx Certified™ Installer.
3. Soxx™ must be installed and stabilized before flow is allowed from culverts and storm outlets.
4. Land surface shall be cleared of debris, including rocks, roots, large clods, and sticks prior to Soxx™ installation.
5. Channel bed shall be made smooth prior to installation of Soxx™.
6. Soil bed may be compacted and graded prior to installation.
7. The upslope end of the Soxx™ shall be installed under the lip of the culvert or outlet drain to ensure initial storm flow contact is on top of the Soxx™, not under or in front of the system.
8. Soxx™ shall be placed parallel to water flow, where socks are tightly abutted to prevent water seepage between and underneath the Soxx™.
9. Once in place, Soxx™ shall be lightly compacted and abutting edges leveled to tighten seal between socks and encourage even water flow over Soxx™ system.
10. Stakes shall be installed through the middle of the Soxx™ on 10 ft (3m) centers, using 2 in (50mm) by 2 in (50mm) by 3 ft (1m) wooden stakes. Top of stakes should be cut off, leaving 3 in (75mm) above the top of the Soxx™.
11. Soxx™ may be seeded at the time of application, seed selection will be determined by the Engineer.



**CHANNEL PROTECTION SECTION**  
NTS



**CHANNEL PROTECTION PROFILE**  
NTS

**FILTREXX® CHANNEL PROTECTION**  
NTS



**Figure 4.2. Engineering Design Drawings for Filtrex Channel Protection - New Channel**

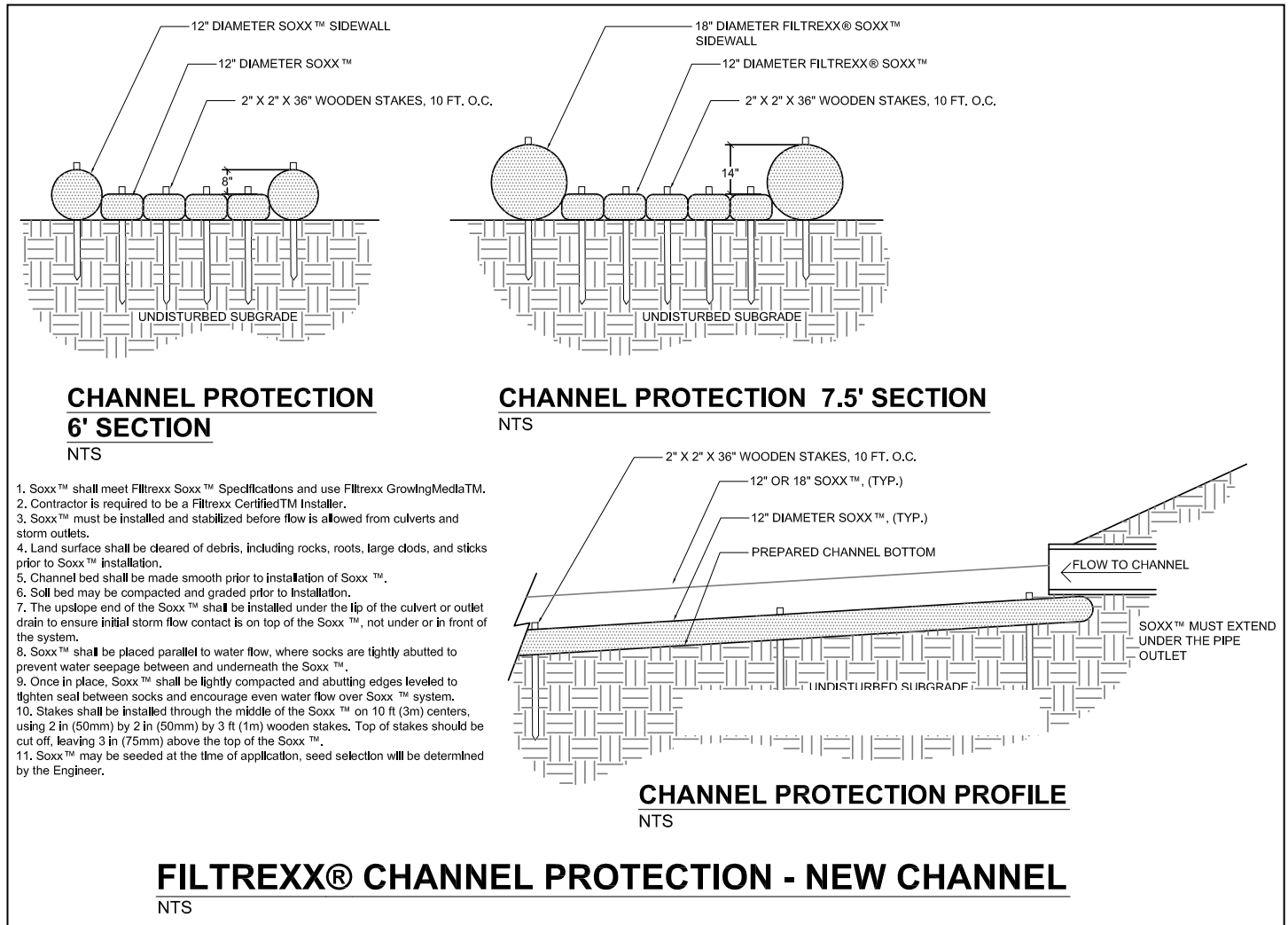


Figure 4.2. Staking Details for Filtrexx® Channel Protection

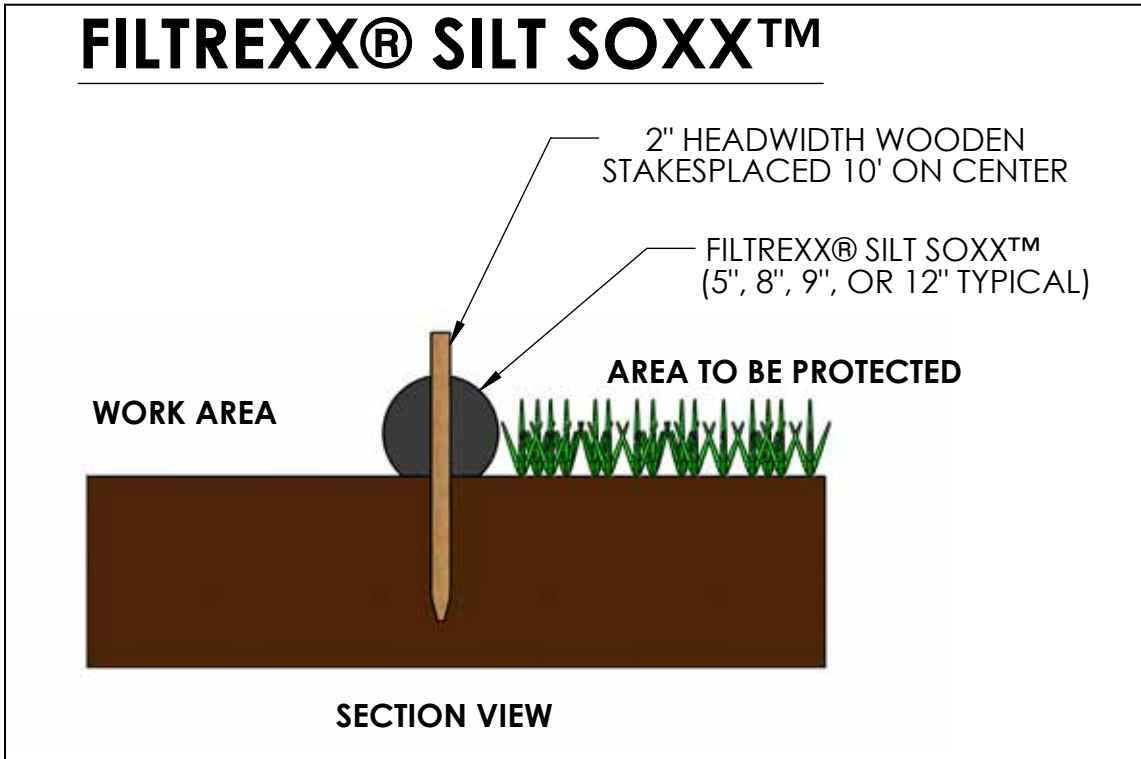


Table 4.2. Flow Dissipater Sizing for Storm Outlets.

Culvert Size	Apron width at pipe	Apron length for low flow	Apron length for high flow
8 in (200mm)	2-3 ft (0.6-1m)	3-5 ft (1-1.5m)	5-7 ft (1.5-2.1m)
12 in (300mm)	3-4 ft (1-1.2m)	4-6 ft (1.2-1.8m)	8-12 ft (2.4-3.6m)
18 in (450mm)	4-6 ft (1.2-1.8m)	6-8 ft (1.8-2.4m)	12-18 ft (3.6-5.5m)
24 in (600mm)	6-8 ft (1.8-2.4m)	8-12 ft (2.4-3.6m)	18-22 ft (5.5-6.7m)
30 in (750mm)	8-10 ft (2.4-3m)	12-14 ft (3.6-4.3m)	22-28 ft (6.7-8.5m)
36 in (900mm)	10-12 ft (3-3.6m)	14-16 ft (4.3-4.9m)	28-32 ft (8.5-9.8m)
42 in (1050mm)	12-14 ft (3.6-4.3m)	16-18 ft (4.9-5.5m)	32-38 ft (9.8-11.6m)
48 in (1200mm)	14-16 ft (4.3-4.9m)	18-25 ft (5.5-7.6m)	38-44 ft (11.6-13.4m)

(Source: Kentucky Erosion Prevention and Sediment Control Field Guide)

